

The control unit has been designed for simple and intuitive use. Wide liquid crystal display. Secure payment system for 24 hours use.

### Accepts



Codes



Smart Coin with a value or a program



Banknotes



Coins and/or tokens



SELECT THE PROGRAM  
01 02 03 04 05 06

PASSAGE SETTINGS  
000100100011011101011

The operator can configure each passage to create personalized programs without the need for external PC

### Dispenses



Receipt



Smart Coin



Coins and/or tokens  
2 hoppers

### AVAILABLE COLOURS



### Structure

- Hot dip galvanized and painted steel structure
- ABS plastic claddings (optional)
- Direct gantry drive with frequency converter
- High resistance rivets "aeronautic" type
- Stainless steel bolts

### Vertical brushes

- Hot dip galvanized steel single cross beam
- Electrical positioning drive with frequency converter
- Double cross over on front and back of the vehicle
- Double inclination and locking by cylinder
- Electronic power control

### Horizontal brush

- Electrical uplift with frequency converter
- Electronic power control
- Stainless steel sliding guides

### Drying

- Contour following stainless steel blade with 3 position tilt
- Electrical uplift with frequency converter
- Stainless steel sliding guides
- Side drying 2 electric blowers

### Standard equipment

- Hydraulic system with dedicated solenoid valves and piping
- Shampoo dosing pump
- Wax dosing pump
- Single festoon supply system (wall hanging)
- Control panel in dedicated wall box
- Fully integrated preset self-service kit

www.aquarama.it



Advanced technology for a lasting success and reliability

### Technical features

#### Machine dimensions (in millimetres)

Washing height	2.100	2.300	2.500	2.800
Machine height	*3.100 (2.980)	*3.300 (3.180)	*3.500 (3.380)	*3.800 (3.680)
Machine width	*3.615 (3.500)			
Washing width	2.420			
Machine depth	*2.400 (1.690)			
Machine weight	1.790	1.850	1.930	2.100
Distance between rails	3.000 (2.500 a richiesta)			
Rails length	10.000	10.000	10.000	12.000

\*Max dimensions with ABS claddings  
( ) Dimensions with standard aluminium cladding

#### Hall or washing bay dimensions for vehicles 5 meters long (in millimetres)

Height	*3.200 (3.100)	*3.400 (3.300)	*3.600 (3.500)	*3.900 (3.800)
Width	**4.000 (4.500)			
Length	*9.900	* **9.600 (9.500)	**(9.000)	

\*Dimensions with ABS claddings  
\*\*With optional safety anti-crush device.  
( ) Dimensions with standard aluminium cladding

#### Technical data sheet

Drive speed	m/min	0-22
Water pressure	Bar	3-5
Air pressure	Bar	8
Voltage	Hz	400 3/N/PE 50
Total power	kW	16
Control voltage	V	24
Drying power	kW	2x3 tetto + 2x4 laterale

#### High pressure pumps (optional)

Water high pressure	Bar	80
---------------------	-----	----

Data are merely indicative and are not binding.

AQUARAMA SRL  
CORSO INGHILTERRA, 24 - 12084 MONDOVI (CN) ITALIA  
TEL. +39/0174 670550 - FAX. +39/0174 670551  
www.aquarama.it - info@aquarama.it



FROM AQUARAMA CREATIVITY AND INNOVATION  
THE FUTURE TAKES SHAPE

#### stargate series

s3 s5 s7 s9 s11





## STANDARD FULL SPECIFICATIONS

### Five frequency converters

The five frequency converters deliver a rapid smooth pass, for a precise wash on every part of the vehicle.



### Drying

Contour following stainless steel horizontal blade, tilting in 3 positions.  
Two horizontal electric blowers 3 kW / each.  
Two lateral electric blowers 4 kW / each.

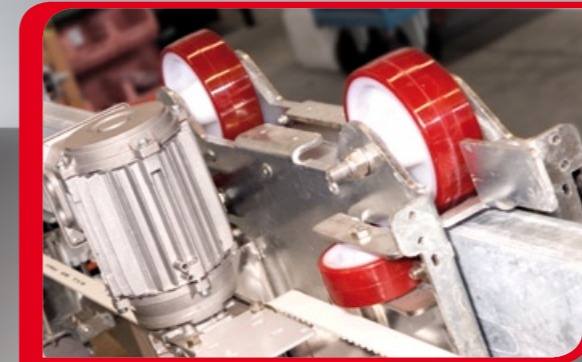

### Low maintenance thanks to self-lubricating materials



### Drive and lift sensor

Measurement movements with two sensors for maximum precision and reliability.

### Wax application

The wax is applied by top nozzles and laterally delivered by nozzles positioned close to the vehicle sides, for a perfect water-repellent effect.



### Tall wash options

Four height options available. Wide vehicle passage. Can be installed in small wash bays.

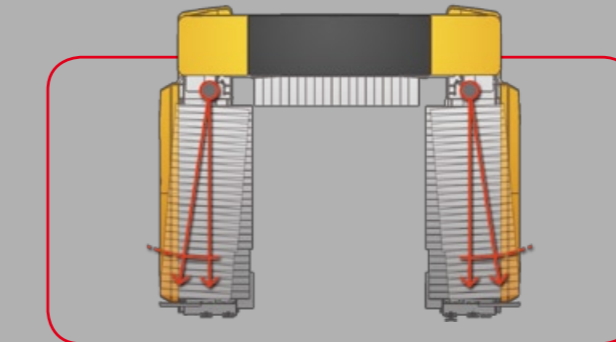
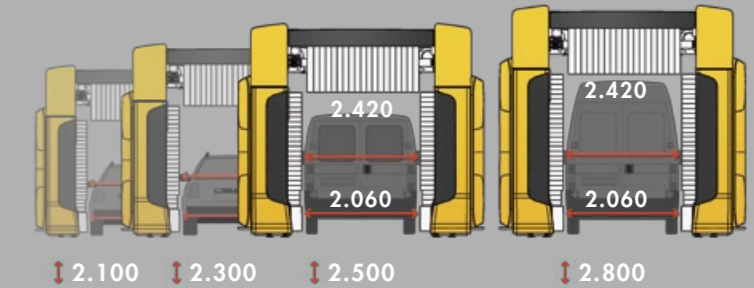

### Sensitive side brushes

Tilting side brushes, electronically controlled, perfectly adapting to the profile of the car.

# stargate Sg

INNOVATIVE DESIGN

TECHNOLOGY BUILT TO LAST

HIGH SPEED OF EXECUTION FOR GREATER PRODUCTIVITY

## A WIDE RANGE OF ACCESSORIES, A FEW EXAMPLES...

### High pressure system pre-wash



#### Wheels

Tilting wheel washer with fully integrated rotating high pressure, for a thorough cleaning of rims, wheel arches and sills.



#### Fixed lateral

Fixed lateral jets for a powerful pre-wash.



#### Horizontal contour following

Contour following stainless steel blade with 3 position tilt delivering maximum water impact for a most complete pre-wash.



### Stainless steel wheel washer

The reversal of rotation and inclination of the brush allows a thorough cleaning of the rims of every dimension.



CABINET

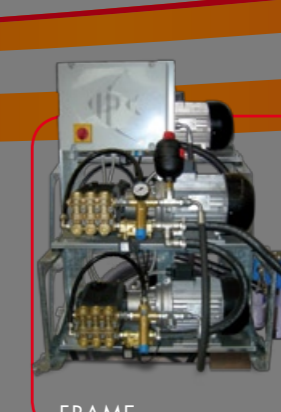

FRAME

### High pressure pumps system

Choices of 21, 42, 84 or 126 liters high pressure pumps system, for a powerful pre-wash. Available in insulated outdoor cabinet or in frame for technical room.

### LED traffic light integrated in the gantry leg



Wide traffic light with LEDs, sliding display. Perfect also in bright light conditions.



**Carlite Brushes**  
HP pre-wash recommended.



**Granwasher Brushes**  
HP pre-wash recommended.